

R3C MALE COAX CAB 3.2/50
PACKAGING IN REEL OF 2500

R299.197.010

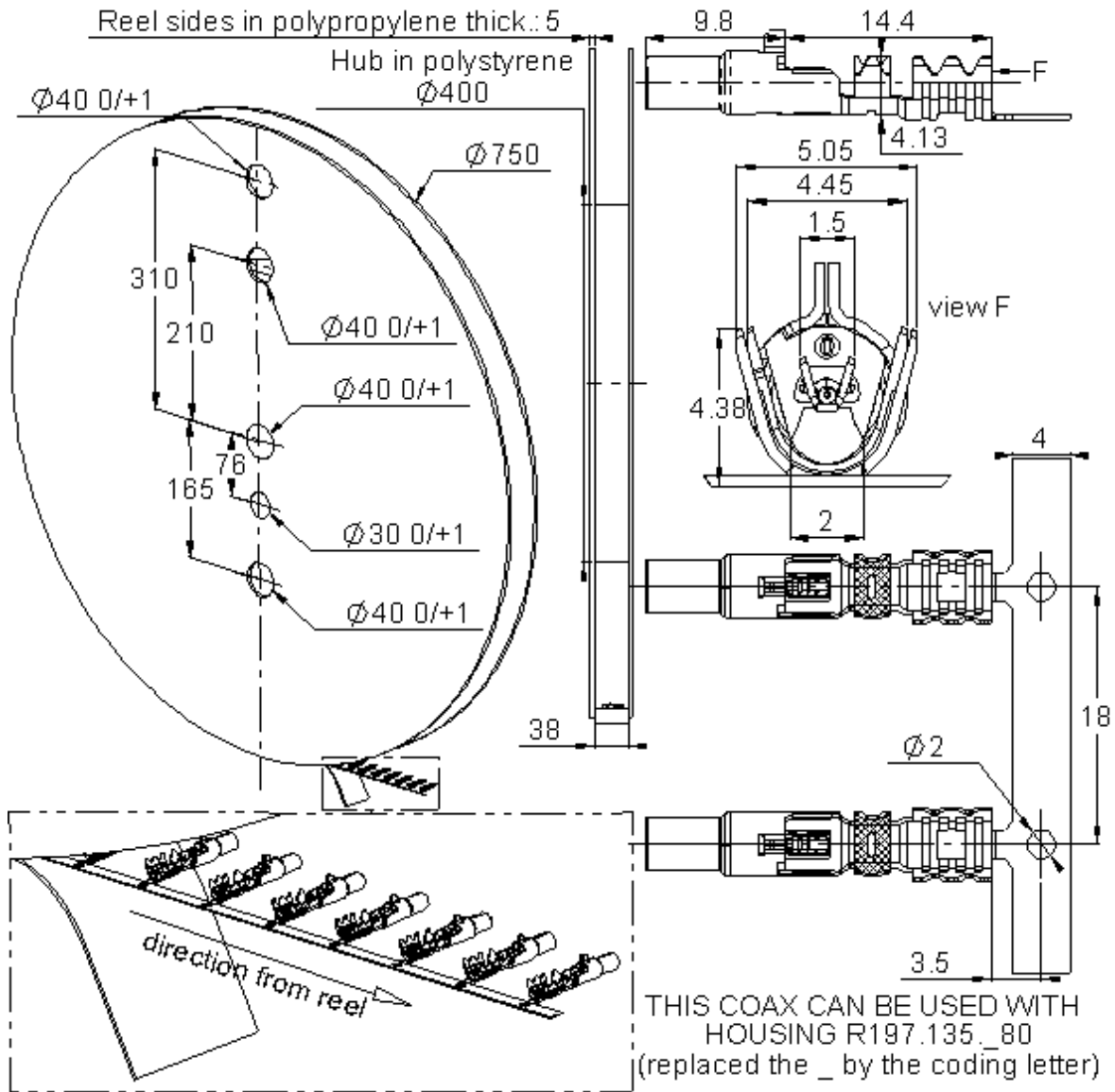

All dimensions are in mm.

COMPONENTS	MATERIALS	PLATING (µm)
BODY	BRONZE	TIN 3 OVER NICKEL 2
CENTER CONTACT	BRONZE	SELECTIVE GOLD+ SELECTIVE TIN
OUTER CONTACT	-	-
INSULATOR	POLYMER	UL CLASSIFICATION
	-	UL94-V0
	-	COLOR
	-	NATURAL

Standard Packaging : 2500+/-2%*

* Nota : possibility of having a maximum of five missing parts consecutively on the tape

Issue : 0915 A

In the effort to improve our products, we reserve the right to make changes judged to be necessary.



R3C MALE COAX CAB 3.2/50
PACKAGING IN REEL OF 2500

R299.197.010

Recommended Stripping dimensions of the RTK cable for R3C male R299.197.010

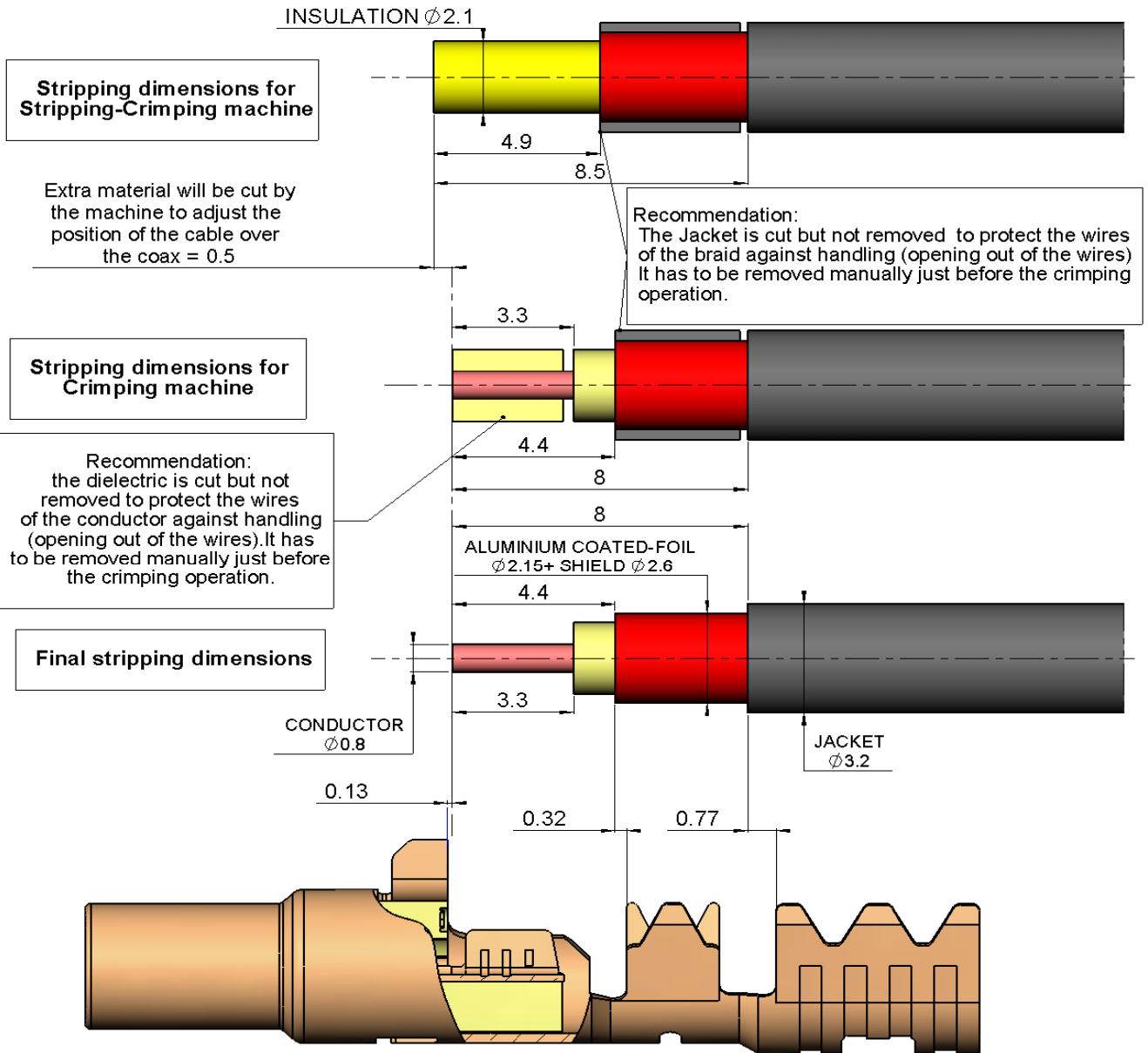

PATENTED

Issue : 0915 A

In the effort to improve our products, we reserve the right to make changes judged to be necessary.

RADIAL 

R3C MALE COAX CAB 3.2/50
PACKAGING IN REEL OF 2500

R299.197.010

crimping height **			
conductor X	braid Y	jacket Z	conductor/body W
1±0,05	2,85±0,05	3,44±0,04	2,5±0,05

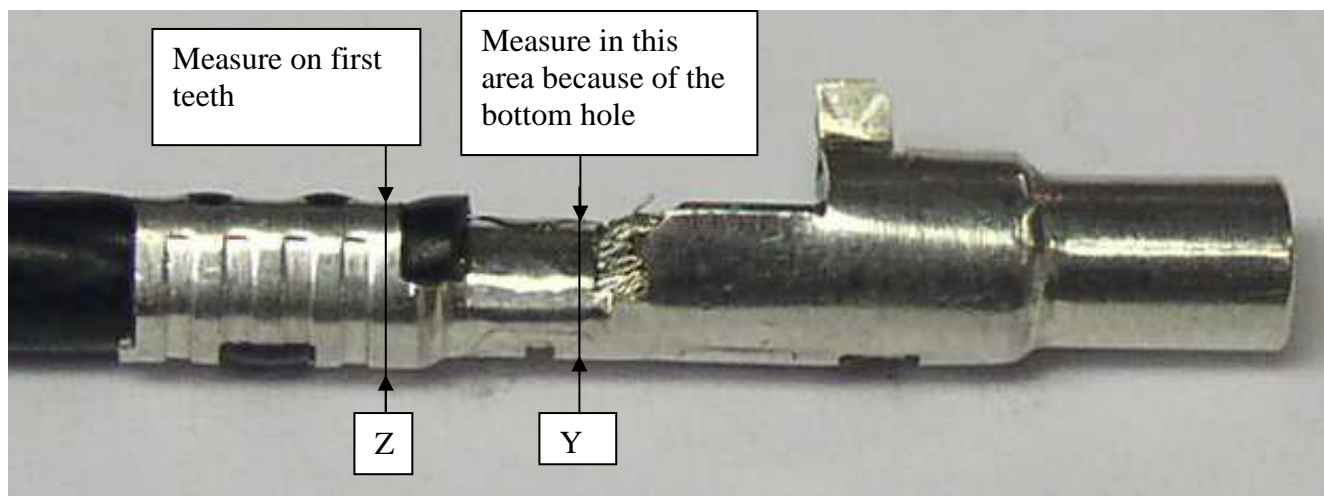
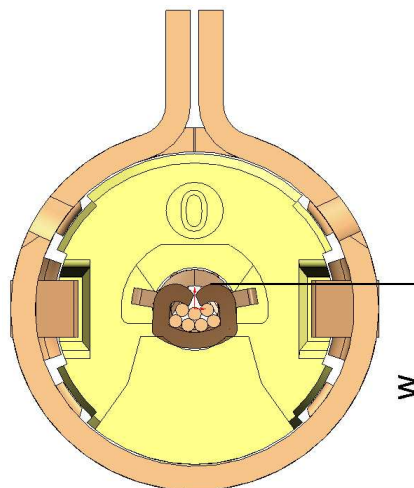
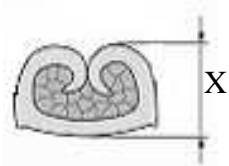

**** CAUTION**

- Before using applicator, make sure the press is calibrated :135,8 mm from the lower dead point up to the base
- Crimping height may change depending on the manufacturer of the cable, for more informations please contact us
- We recommend to make electrical test after each set up of the applicator:
 - Outer and center contact continuity+Dielectric withstanding voltage 800Vrms, 50Hz
 - Insulation resistance 1000 Mohms
 - Cable retention = 110Newton mini during 5 seconds with electrical continuity

Issue : 0915 A

In the effort to improve our products, we reserve the right to make changes judged to be necessary.

